

PROPERTY TYPE	LOCATION	LOT NO.	AREA (ACRES)	TERM
Single Storey Detached House	Kg Kupang (House No 22, Spg 331)	15126	0.468	Lease 55 Years (1979)

**Direction:**

Approach to the subject land is via Jalan Tutong wherefrom Simpang 331 branches off onto which the subject land has frontage.

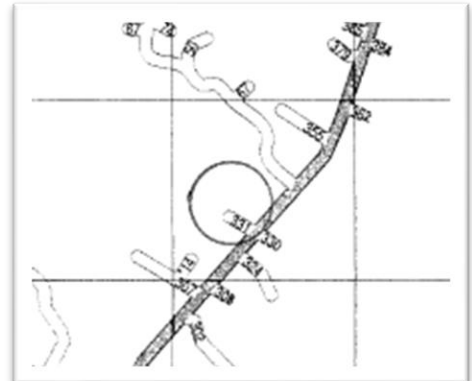

## SALE OF PROPERTY BY TENDER

Notice is hereby given that all that one (1) parcel of land described below shall be sold by public tender pursuant to an Order for Sale obtained on the 22<sup>nd</sup> day of July 2019.

### DESCRIPTION OF PROPERTY

- Title of land : EDR No. TU 13986, LOT NO. 15126, one (1) parcel of land together with the building erected thereon situated at Kampung Kupang, Mukim Keriam, Tutong District
- Location : House No. 22, Simpang 331, Jalan Tutong, Kampung Kupang
- Nature/Term : Lease of 55 years with effect from 3<sup>rd</sup> September 1979
- Land Area : 0.468 acre (0.1894 hectare)
- Improvement : Single storey detached house

### PARTICULARS OF TENDER

1. The minimum reserve price for the Property is **BND83,000.00**.
2. The tender should clearly identify the name and address of the person making the tender and the sum tendered.
3. The Property will be sold subject to the Conditions of Tender. A copy of the Conditions of Tender and details of the Property may be obtained from the office of the Chargee's solicitors whose name and address are stated below during normal working hours.

**MESSRS PENGIRAN IZAD & LEE**  
6<sup>th</sup> Floor, Bangunan Hj Ahmad Laksamana Othman  
38-39, Jalan Sultan  
Bandar Seri Begawan BS8811  
Brunei Darussalam

4. All tenders must reach the said solicitors not later than **5.00 p.m. on Monday, the 29<sup>th</sup> day of July 2024**.

The Chargee reserves the right to bid for the Property.

All enquiries relating to this Tender can be made to **MESSRS PENGIRAN IZAD & LEE** at 6<sup>th</sup> Floor, Bangunan Hj Ahmad Laksamana Othman, 38-39, Jalan Sultan, Bandar Seri Begawan BS8811, Brunei Darussalam or contact telephone nos. 2232945/6/7/8.